

DL3 Datalogger



RESOL®

beginning with firmware version 2.2.0

Mounting Operation Web interface



11209030



The Internet portal for easy and secure access to your system data – www.vbus.net

Thank you for buying this RESOL product.
Please read this manual carefully to get the best performance from this unit.
Please keep this manual carefully.

en

Manual

www.resol.com

Safety advice

Please pay attention to the following safety advice in order to avoid danger and damage to people and property.

- Danger of electric shock: Do not use the device if it is visibly damaged.
- If the mains adapter or its cable is damaged, it has to be replaced by an identical mains adapter, which is available from the manufacturer or its customer service.

The device must not be used by children or persons with reduced physical, sensory or mental abilities or without any experience and knowledge. Make sure that children do not play with the device!

Only connect accessories authorised by the manufacturer to the device.

Make sure that the housing is properly closed before commissioning the device.

Target group

These instructions are exclusively addressed to authorised skilled personnel.

Only qualified electricians should carry out electrical works.

Initial commissioning must be effected by authorised skilled personnel.

Authorised skilled personnel are persons who have theoretical knowledge and experience with the installation, commissioning, operation, maintenance, etc. of electric/electronic devices.

Instructions

Attention must be paid to the valid local standards, regulations and directives!

Subject to technical change. Errors excepted.

Information about the product

Proper usage

The RESOL DL3 Datalogger is connected to RESOL controllers via the VBus® interface. It enables logging of system data and parameterisation of a solar thermal system.

- Use in dry interior rooms only.
- Avoid ambient temperatures lower than 0 °C or higher than 40 °C.
- Do not expose to strong electromagnetic fields.

Any use beyond this is considered improper.

Proper usage also includes compliance with the specifications given in this manual.

Improper use excludes all liability claims.



Note

Strong electromagnetic fields can impair the function of the device.

- ➔ Make sure the device as well as the system are not exposed to strong electromagnetic fields.

EU Declaration of conformity

The product complies with the relevant directives and is therefore labelled with the CE mark. The Declaration of Conformity is available upon request, please contact the manufacturer.



Scope of delivery

The scope of delivery of this product is indicated on the packaging label.

Storage and transport

Store the product at an ambient temperature of 0 ... 40 °C and in dry interior rooms only.

Transport the product in its original packaging only.

Cleaning

Clean the product with a dry cloth. Do not use aggressive cleaning fluids.

Data security

Change and note down the remote access password and keep it in a suitable place. We recommend regular backups of the data stored on the device via SD card. In order to delete personal data, reset the device to its factory settings before disposal / decommissioning / transfer to a third party.

Decommissioning

1. Disconnect the device from the power supply.
2. Dismount the device.

Disposal

- Dispose of the packaging in an environmentally sound manner.
- At the end of its working life, the product must not be disposed of as urban waste. Old appliances must be disposed of by an authorised body in an environmentally sound manner. Upon request we will take back your old appliances bought from us and guarantee an environmentally sound disposal of the devices.



Description of symbols

Warnings are indicated with a warning symbol!

Signal words describe the danger that may occur, when it is not avoided.

ATTENTION means that damage to the appliance can occur.



→ It is indicated how to avoid the danger described.



Note

Notes are indicated with an information symbol.

→ Texts marked with an arrow indicate one single instruction step to be carried out.

1. Texts marked with numbers indicate several successive instruction steps to be carried out.

Cross reference



A book symbol indicates a cross reference to another chapter.

Contents

1	Overview	5	8	Basic configuration	19
2	Included	6	8.1	Finding the DL3 Datalogger by means of the DeviceDiscoveryTool.....	20
3	Installation	6	8.2	Changing the web interface language.....	20
3.1	Wall mounting.....	7	8.3	Changing the live data display language	20
3.2	Electrical connection.....	7	8.4	Changing the user password.....	20
3.3	VBus®/Data communication.....	8	8.5	Changing the device name.....	20
3.4	Sensors.....	8	8.6	Configuring date and time information	21
3.5	LAN connection.....	8	8.7	Configuring automatic firmware update configuration.....	21
4	Operating controls, menu and connections	8	8.8	Carrying out a VBus® specification update	22
4.1	Operating control LED	8	8.9	Configuring the remote access.....	22
4.2	Buttons.....	9	9	Advanced configuration	23
4.3	Selecting options / menu points and adjusting values.....	9	9.1	Accessing the DL3 Datalogger over the Internet without VBus.net.....	23
4.4	Display.....	9	9.2	BACnet access.....	24
4.5	Configuration.....	11	9.3	Log interval configuration.....	27
4.6	LAN connector.....	14	9.4	Log mode configuration.....	27
4.7	USB interface.....	14	9.5	Network configuration.....	27
4.8	SD memory card slot.....	15	9.6	Data display configuration	27
4.9	Power supply connection.....	15	9.7	Filter configuration.....	29
4.10	VBus® connection.....	15	9.8	Public access configuration.....	29
5	Accessing the DL3 Datalogger over the Internet with the VBus.net visualisation portal	16	10	Firmware update with SD card	30
6	Accessing the DL3 Datalogger with the RPT Parameterisation Tool via VBus.net	16	11	Data export	30
7	Web interface	16	11.1	Data export over SD card.....	30
7.1	Menu.....	17	11.2	Data export over web interface	31
7.2	Menu overview.....	18	12	FTP access configuration	31
7.3	Data	18	13	SSH configuration	31
7.4	Erasing logged data.....	18	14	Eliminating errors	32
7.5	Displaying firmware versions	19	15	Ordering software	33
7.6	Displaying the Device Date/Time.....	19	16	Appendix	33
7.7	Displaying network configuration.....	19	16.1	Possible export file formats	33
7.8	Displaying data communication.....	19	16.2	Unit conversion table.....	34
7.9	Displaying the memory capacity.....	19	17	Accessories	34
7.10	Displaying the remote access.....	19	18	Spare parts	34

1 Overview

The DL3 Datalogger is used for logging data of up to 6 RESOL controllers and permits the visualisation via www.VBus.net and the parameterisation via RPT. Get a comprehensive overview of all controllers connected with the large full graphic display, all important settings are directly adjustable on the DL3. The integrated sensor and impulse inputs can measure and log temperatures – even without a controller. The DL3 is furthermore equipped with a BACnet functionality for BACnet conform transmission of data and can thus be used in a building management system.

- Data logging and parameterisation of up to 6 VBus® master devices
- Measuring and logging temperature values – even without a controller
- BACnet functionality
- Integrated heat quantity measurement (only if the device is delivered with a firmware version beginning with 2.2.0)
- Remote access to the system via the VBus.net visualisation portal
- Comfortable system parameterisation via the RESOL RPT Parameterisation Tool possible
- Data transfer via SD card
- Firmware updates via Internet or SD card
- Suitable for all RESOL controllers with VBus®

Dimensions and minimum distances

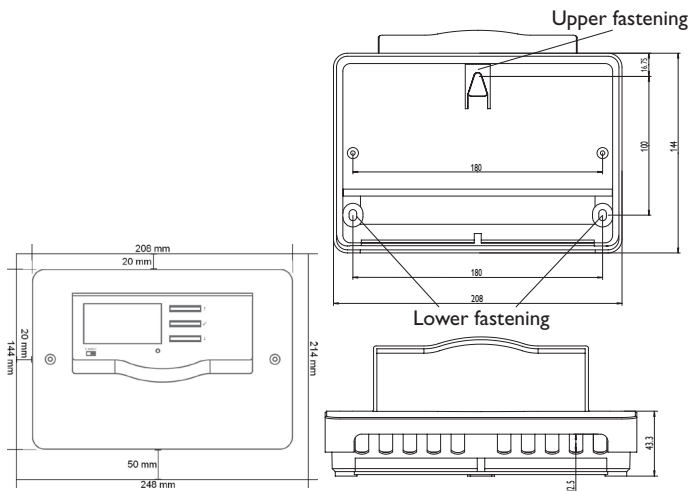

Technical data

Housing: plastic, PC-ABS and PMMA

Protection type: IP 20/EN 60529

Protection class: III

Ambient temperature: 0... 40 °C

Maximum altitude: 2000 m above MSL

Dimensions: 144 x 208 x 43 mm

Mounting: wall mounting, mounting into patch panels possible

Display: full graphic display for status visualisation and operating control LED

Inputs: for 3 Pt500, Pt1000, KTY or impulse sensors, 1 current loop interface 0(4)-20 mA

Operation: 3 push buttons and 1 slide switch

Interfaces: 6 x RESOL VBus® for the connection to the controller (slave), 1 x SD card slot, 1 x LAN (10/100), 1 x USB master

Power supply:

Mains adapter: 100 – 240V~, 1A/12V=, 1 A (Level 6)

Datalogger: 12V=, 200 mA

Electrical energy source: ES1 (EN 62368-1)

Electrical power source: PS1 (EN 62368-1)

Thermal energy source: TS1 (EN 62368-1)

Mechanical energy source: MS1 (EN 62368-1)

Memory: 160 MB internal memory, with a logging interval of 5 min. sufficient for:

- 18 months for a systems with one DeltaSol® MX, 3 EM, 3 heating circuits and 1 HQM
- 24 months for a system with one DeltaSol® MX, 1 EM and 1 heating circuit
- 30 months for a system with one DeltaSol® MX



Use mains adapter in dry interior rooms only.



Mains adapter protection class: II

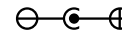

Coaxial connector polarity:
internal: plus
external: minus (GND)

2 Included

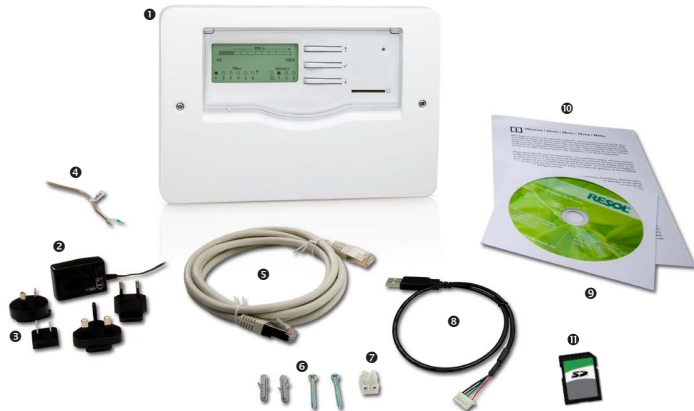

If one of the items mentioned below is missing or defective, please contact your distributor:

- ❶ DL3 Datalogger
- ❷ Mains adapter
- ❸ Interchangeable mains adapter plugs (EURO, UK, USA, AUS)
- ❹ VBus® cable
- ❺ Network cable (CAT5e, RJ45), 1 m
- ❻ Wall plugs and screws
- ❼ Terminal block for extending the VBus® cable
- ❽ USB adapter cable
- ❾ Service CD (manual included)
- ❿ Manual (picture similar to original product)
- ⓫ SD card

3 Installation

ATTENTION! ESD damage!



Electrostatic discharge can lead to damage to electronic components!

→ Take care to discharge properly before touching the inside of the device. To do so, touch a grounded surface such as a radiator or tap!

ATTENTION! Short circuit!



A short circuit can lead to damage to electronic components!

→ Close the housing before establishing the mains connection!

If the mains adapter or its cable is damaged, it has to be replaced by an identical mains adapter, which is available from the manufacturer or its customer service.

Do not use the device if it is visibly damaged!

3.1 Wall mounting

The unit must only be located in dry interior rooms. It is not suitable for installation in hazardous locations and should be protected against electromagnetic fields. Please pay attention to separate routing of sensor cables and mains cables.

1. Choose a mounting location.
2. Unscrew the crosshead screw from the cover and remove the cover.
3. Mark the upper fastening point on the wall. Drill and fasten the enclosed wall plug and screw leaving the head protruding.
4. Hang the housing from the upper fastening point and mark the lower fastening points (centres 180 mm)
5. Drill 2 holes (Ø 6 mm) and insert the wall plugs.
6. Fasten the housing to the wall with the lower fastening screw and tighten.
7. Carry out the electrical connection according to the terminal allocation.
8. Reattach the cover and fasten it using the crosshead screws included.

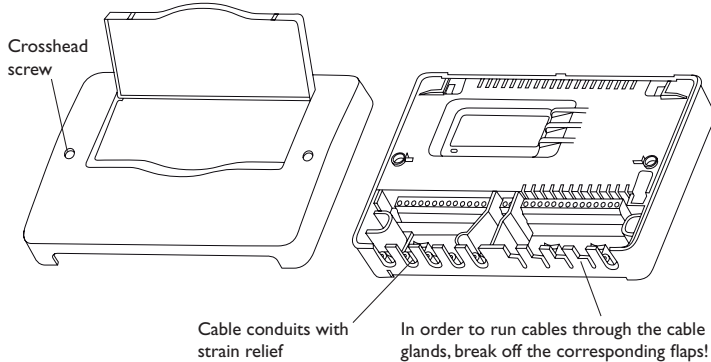

3.2 Electrical connection

i Note Connecting the device to the power supply must always be the last step of the installation!

Carry out the connection of the Datalogger (pos. 1) to other modules in the order described below:

1. Connect the data cable (RESOL VBus®, 4) to the controller 12 and the DL3 1. If necessary, extend the cable using the terminal block included 7 and a common two-wire cable.
2. Connect the mains adapter 2 / 3 to the DL3 and to a mains socket.
3. For a direct connection to a router or a PC, connect the Datalogger to a router or a PC using the network cable (included with the DL3, 9).

The cables carry low voltage and must not run together in a cable conduit with cables carrying a voltage higher than 50 V (please pay attention to the valid local regulations).

Power supply is carried out via an external mains adapter. The supply voltage of the mains adapter must be 100–240V~ (50–60 Hz).

The mains adapter and a VBus® cable are included with the DL3.

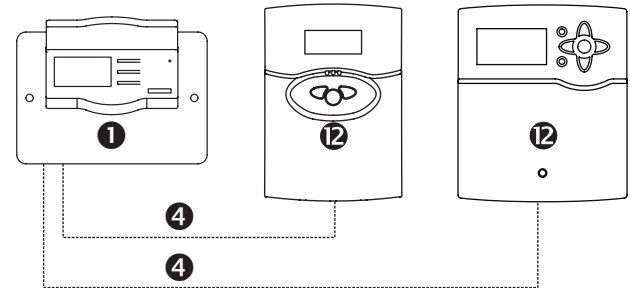

3.3 VBus®/Data communication

The DL3 Datalogger is connected to one or several controllers via VBus® cables. The corresponding terminal allocation is described in the controller manual. The VBus® cable can be extended using the terminal block included and a common two-wire cable.

VBus® connection at the terminals:

1/2 = VBus® connection 1 (slave)

3/4 = VBus® connection 2 (slave)

5/6 = VBus® connection 3 (slave)

7/8 = VBus® connection 4 (slave)

9/10 = VBus® connection 5 (slave)

11/12 = VBus® connection 6 (slave)

To the VBus® connections 1 ... 6, master devices (controllers) can be connected.

3.4 Sensors

Connect the sensors to the following terminals with either polarity:

- \perp / S1 ... S3 = Temperature sensors 1 to 3 / impulse sensors 1 to 3



Note

Please pay attention to chap. 4.5.5 Sensors on page 12

Connect the sensor using a 0(4)-20 mA signal as specified by the manufacturer to the following terminals:

- \perp / CL = Current loop interface 0(4)-20 mA

3.5 LAN connection

The DL3 Datalogger can be connected to a computer or a router by using a network cable (CAT5e, RJ45).

- ➔ Connect the network cable included to the network adapter of the computer or the router.



For the next step of commissioning, see chap. 8 **Basic configuration** on page 19.

4 Operating controls, menu and connections

The following elements are featured on/in the housing of the DL3 Datalogger:

- ① push buttons
- ② SD memory card slot
- ③ LAN socket
- ④ power supply socket
- ⑤ sensor inputs (Pt1000, Pt500, KTY or impulse)
- ⑥ current loop interface 0(4) - 20 mA
- ⑦ VBus® connections

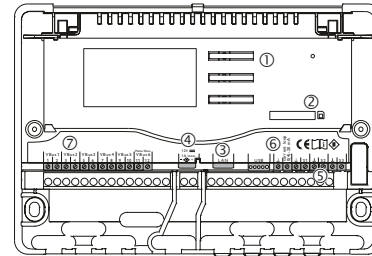

Positions of the operating controls and connections

4.1 Operating control LED

The operating control LED indicates the operating status of the DL3 Datalogger by issuing flashing signals.

Colour	Permanent	Flashing
Green	The device is ready for operation/SD card can be removed.	Do not remove the SD card! Data are being copied onto the SD card.
Red		An error has occurred. The error will be indicated on the display.
Red/green		The device is booting.
OFF	No power supply.	

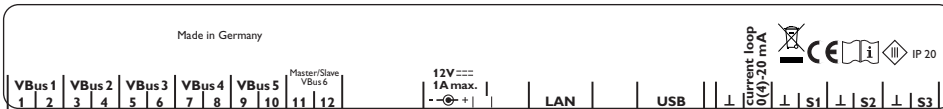

4.2 Buttons

The device is operated via the three push buttons next to the display. The push buttons have the following functions:

- Button ↑: Scrolling upwards
- Button ✓: Confirming
- Button ↓: Scrolling downwards

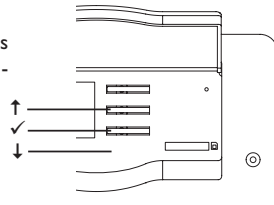

4.3 Selecting options / menu points and adjusting values

Values and adjustments can be changed in different ways:

An option can be selected by pressing buttons ↑ and ↓ and then confirming by pressing button ✓. Now the option can be activated: By pressing buttons ↑ and ↓, **Yes** can be selected to activate, **No** to deactivate the option. The selection can be confirmed by pressing button ✓.

Numeric values can be adjusted by means of a slide bar. The minimum value is indicated to the left, the maximum value to the right. The number above the slide bar indicates the current adjustment. By pressing buttons ↑ and ↓, the upper slide bar can be moved to the left or to the right.



Only after the adjustment has been confirmed by pressing button ✓ will the number on the right-hand side above the slide bar indicate the new value. The new value will be saved if it is confirmed by pressing button ✓ again.

If only one item of several can be selected, they will be indicated with "radio buttons". When one item has been selected, the radio button in front of it is filled.

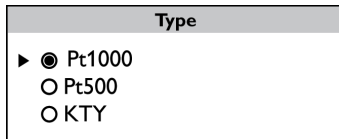

If more than one item of several can be selected, they will be indicated with checkboxes. When an item has been selected, an **x** appears inside the checkbox.

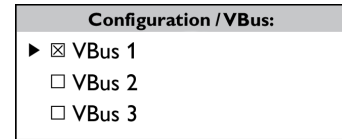

4.4 Display

During normal operation, the DL3 Datalogger indicates the status display (see fig. page 9). buttons ↑ and ↓ can be used to switch between the displays.

If no button has been pressed within a couple of minutes, the display illumination is switched off.

→ Press any key to reactivate the display illumination.

4.4.1 Status display

During normal operation, the DL3 Datalogger indicates the status display with the following information:

- Data memory progress bar (fill level)
- Remaining logging time in days
- VBus® devices connected
- Sensors connected

The data memory progress bar is divided into 10 segments. Each segment represents 10% of the memory capacity.

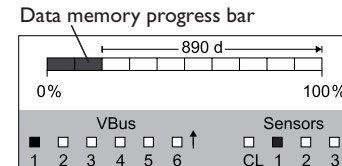

- Segment filled: The memory capacity of this segment is fully occupied.
 - Segment flashing: The memory capacity of this segment is partly occupied.
- The arrow above the data memory progress bar indicates the remaining logging time in days.

In the bottom left-hand area of the status display, each VBus® device connected with a functioning VBus® communication is indicated by a corresponding filled checkbox. In the bottom right-hand area of the status display, each sensor connected is indicated by a corresponding filled checkbox.

4.4.2 Network display

In the network display, information about the network connection is displayed. In the centre, the IP address of the DL3 is displayed. When the DL3 is connected to the Local Area Network (LAN), a house is indicated on the left-hand side of the display.

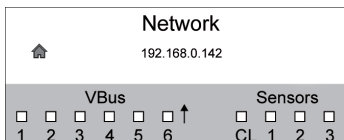

When the DL3 is also connected to the Internet, a globe is indicated on the right-hand side of the display (the house is not indicated any more in that case).

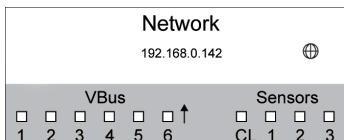

If the DL3 has not been assigned with an IP address, none of the symbols are indicated, the line remains empty.



Note

If a static IP address has been assigned to the DL3, the IP address and the house/globe symbol appear as soon as the network cable has been connected.

4.4.3 VBus® display

In the VBus® display, VBus® information about the VBus® devices connected is indicated.

In the left-hand area of the display, the number of bytes received (Rx) is indicated. In the right-hand area of the display, the number of bytes transmitted (Tx) is indicated. A VBus® device connected with a functioning VBus® communication is indicated by a corresponding filled checkbox in the bottom area of the display.

Each VBus® device has its own display. The connections VBus® 1 to VBus® 6 are displayed each in their own display.

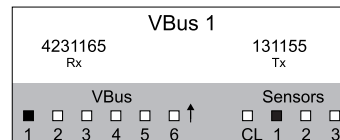

→ In order to leave the status level and access the VBus® displays, press button ↓. The display indicates information about the VBus® device.

→ In order to access information about further VBus® devices, scroll down by pressing button ✓.

4.4.4 Sensor display

In the sensor display, information about the sensors connected is indicated.

In the left-hand area of the display, the resistance value of the corresponding sensor is indicated. In the right-hand area of the display, the temperature value of the corresponding sensor is indicated in °C.

A sensor connected is indicated by a corresponding filled checkbox in the bottom area of the display.

Each sensor has its own display. The data of the inputs CL and S1 to S3 are displayed each in their own display.

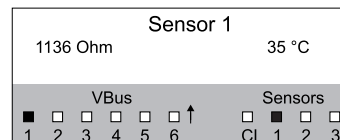

→ In order to leave the status level and access the sensor displays, press button ↓.

→ Press button ↓ to scroll down through the VBus® displays until the sensor displays appear.

→ In order to access information about further sensors, scroll down by pressing button ↓.

4.4.5 Heat quantity display

Display of the heat quantity produced. For this purpose, the heat quantity measurement option has to be activated. The accumulated heat quantity can be set back to zero. For information about adjusting the heat quantity measurement, see chap. 4.5.4 **HQM** on page 11.

4.5 Configuration

In the **Configuration** menu, different adjustments can be made.

➔ In order to access the menu, press button ✓ for approx. 3 s.

Menu structure

The menu consists of the following submenus:

- Language
- Time
- VBus
- HQM
- Sensors
- Logging
- Network
- Erase
- Version x.x

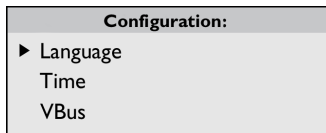

➔ In order to access the adjustment mode of a submenu, select the desired submenu by pressing buttons ↑ and ↓, and confirm with button ✓.

4.5.1 Language

In the **Language** submenu, the menu language can be selected.

1. Select the desired language by pressing buttons ↑ and ↓.
2. Briefly press button ✓ to confirm the selection.
3. In order to get back to the **Configuration** menu, select **Back** and confirm by pressing button ✓.

4.5.2 Date and time

In the **Time** submenu, the date and time can be adjusted.

1. To adjust the date, select the menu item **Date** in the **Time** submenu.
2. Adjust the year by pressing buttons ↑ and ↓, and confirm with button ✓.

Now the month is displayed, too. As soon as it has been adjusted and confirmed, the day appears as well.

3. Adjust and confirm the current month and day as described above.
4. To adjust the time, select the menu item **Time** in the **Time** submenu.

5. Adjust the hours by pressing buttons ↑ and ↓, and confirm with button ✓.
6. Adjust the minutes by pressing buttons ↑ and ↓, and confirm with button ✓.

4.5.3 VBus

In the **VBus** submenu, the monitoring of the VBus® connections can be activated.

1. Select the desired VBus® connection by pressing buttons ↑ and ↓, and confirm with button ✓.
2. To activate the monitoring of the VBus® connection, select **Yes**. To deactivate the monitoring of the VBus® connection, select **No**.

If an error occurs in a VBus® connection, the operating control LED flashes and the message **VBus (1 ... 6) no signal** appears on the display.

4.5.4 HQM



Note

If the device was delivered with a firmware version lower than 2.2.0 and has been updated later, the heat quantity measurement option will not be available.

In the HQM menu, heat quantity measurement can be activated. In order to do so, proceed as follows:

1. Select the menu item **Activated** and confirm by pressing button ✓.
2. In order to activate the heat quantity measurement, select **Yes** and confirm by pressing button ✓. In order to deactivate it, select **No**.

If the heat quantity measurement has been activated, the following adjustments can be made:

- Fluid type
- Concentration
- Reset

In order to adjust the fluid type, proceed as follows:

3. Select the menu item **Fluid type** by pressing buttons ↑ and ↓, and confirm with button ✓.
4. Select the fluid type by pressing buttons ↑ and ↓, and confirm with button ✓.

If Propylene or Ethylene glycol has been selected, the antifreeze concentration has to be adjusted:

5. Select the menu item **Concentr.** by pressing buttons ↑ and ↓ and confirm with button ✓.
6. Adjust the concentration by pressing buttons ↑ and ↓, and confirm with button ✓.

In order to set back the heat quantity to zero, a reset can be run:

1. Select the menu item **Reset** by pressing buttons \uparrow and \downarrow , and confirm with button \checkmark .
2. In order to set back the heat quantity, select **Yes** and confirm by pressing button \checkmark .



Note

If the heat quantity measurement has been activated, the corresponding sensors will be automatically allocated in the Sensor menu:

S1 = Pt1000, flow sensor

S2 = Pt1000, return sensor

S3 = impulse input 1/Imp

4.5.5 Sensors

In the **Sensors** submenu, the sensor type and an offset can be adjusted for each sensor input.

Sensor type

For the sensor inputs S1 ... S3, the following sensor types are available:

- None
- Pt1000
- Pt500
- Impulse
- KTY



Note

The selection **Offset** is not available when the sensor type Impulse has been selected.

In order to adjust the sensor type, proceed as follows:

1. Select the desired sensor by pressing buttons \uparrow and \downarrow , and confirm with button \checkmark .
2. Select the menu item **Type** and confirm by pressing button \checkmark .
3. Select the right sensor type and confirm by pressing button \checkmark .

If the sensor type **Impulse** has been selected, the impulse rate can be adjusted. In order to adjust the impulse rate, proceed as follows:

1. Select the desired sensor by pressing buttons \uparrow and \downarrow , and confirm with button \checkmark .
2. In the corresponding sensor menu, select the menu item **Vol./Imp.**
3. Adjust the desired value by pressing buttons \uparrow and \downarrow , and confirm with button \checkmark .

Sensor offset

In order to adjust an offset for the sensor inputs S1 ... S3, proceed as follows:

1. Select the desired sensor by pressing buttons \uparrow and \downarrow , and confirm with button \checkmark .
2. Select the menu item **Offset** and confirm by pressing button \checkmark .
3. Adjust the desired value by pressing buttons \uparrow and \downarrow , and confirm with button \checkmark .

If the current loop interface is used, the type can be adjusted. The following types are available:

- None
- 0 - 20 mA
- 4 - 20 mA
- Si-420TC

In order to adjust the type, proceed as follows:

1. Select the menu item **Current loop** by pressing buttons \uparrow and \downarrow , and confirm with button \checkmark .
2. Select the **Type** submenu.
3. Select the right type and confirm by pressing button \checkmark .

If an error occurs in a sensor connection, the operating control LED flashes and the message **Input (1 ... 4) no signal** appears on the display.

4.5.6 Logging

In the **Logging** submenu, the following adjustments can be made:

- Interval
- Logging type
- SD card (only if an SD card has been inserted into the SD card slot)

When **Interval** has been selected, the logging interval can be adjusted. In order to adjust the interval, proceed as follows:

1. Select the number of minutes by pressing buttons \uparrow and \downarrow , and confirm with button \checkmark .
2. Select the number of seconds by pressing buttons \uparrow and \downarrow , and confirm with button \checkmark .

In the menu item **Log. type**, one of the following logging types can be selected:

- linear
- cyclic

When **linear** is adjusted in the **Logging type** adjustment channel, data logging will stop if the capacity limit is reached. If **cyclic** is adjusted, the oldest data logged into the internal memory will be overwritten as soon as the capacity limit is reached.

When **Log. type** has been selected, the logging type can be adjusted. In order to adjust the logging type, proceed as follows:

- ➔ Select the desired logging type by pressing buttons ↑ and ↓, and confirm with button ✓.

In the menu item **SD card**, the following adjustments can be made:

- Backup
- Format card
- Update

When **Backup** has been activated, the data logged over the previous day will be copied onto the SD card at midnight (00:00), using the VBus® data format. The data remain in the internal memory as well.

When **Format card** has been selected, the SD card will be formatted. In order to format the SD card, proceed as follows:

1. Select the menu item **Format card** by pressing buttons ↑ and ↓, and confirm with button ✓.
2. To format the card, select **Yes** and confirm by pressing button ✓.

During the formatting process, the message **Please wait...** is indicated. When formatting has been completed, the message **Successful!** appears. Press any key to leave the menu item.

When an SD card with a firmware update is inserted, the enquiry **Update?** is indicated on the display.

- ➔ To run the update, select **Yes** and confirm by pressing button ✓ (see chap. 10 **Firmware update with SD card** on page 30).

If no firmware update is found on the memory card, the query **Copy data?** appears.

- ➔ To copy the data logged in the internal memory, select **Yes** and confirm by pressing button ✓; to cancel the function, select **No** and confirm by pressing button ✓.

4.5.7 Network

In the **Network** submenu, the following adjustments can be made:

- VBus.net
- LAN

VBus.net can be used to access the DL3 Datalogger over the Internet without adjusting the router (see chap. 5 **Accessing the DL3 Datalogger over the Internet with the VBus.net visualisation portal** on page 16). In order to activate VBus.net, proceed as follows:

1. Select **VBus.net** by pressing buttons ↑ and ↓, and confirm with button ✓.
2. Select the menu item **Log in** and confirm by pressing button ✓.
3. To register the DL3 Datalogger for **VBus.net**, select **Yes** and confirm by pressing button ✓.
4. Select the menu item **Log-in code** by pressing buttons ↑ and ↓, and confirm with button ✓.

The DL3 Datalogger generates a 8-10-digit code and registers its address with the RESOL server. To access the data, a user account at VBus.net is required. In order to register with the server, proceed as follows:

5. Open a user account at www.vbus.net.
6. Choose a user name and password.
7. Enter the code generated by the DL3 in the user account.

In the **LAN** submenu, the following adjustments can be made for accessing the Datalogger over LAN:

- Auto configuration
- Address
- Mask
- Recover IP

When **Auto configuration** has been activated, the IP address and IP net mask are indicated, but cannot be adjusted. If **Auto configuration** has been deactivated, the IP address and IP net mask must be adjusted. In order to make adjustments, proceed as follows:

1. Select **Auto configuration** by pressing buttons ↑ and ↓, and confirm with button ✓.
2. To deactivate Auto configuration, select **No** and confirm by pressing button ✓.
3. Adjust the IP address by pressing buttons ↑ and ↓, and confirm with button ✓.
4. Adjust the IP net mask by pressing buttons ↑ and ↓, and confirm with button ✓.

The menu item **Recover IP** can be used to automatically retrieve a new IP address for the DL3 in the case that the previous one is lost. In order to adjust the automatic IP address configuration, proceed as follows:

1. Select the menu item **Recover IP** by pressing buttons ↑ and ↓, and confirm with button ✓.
2. To activate Recover IP, select **Yes** and confirm by pressing button ✓.

Now the interval for the automatic IP address configuration can be adjusted. In order to do so, proceed as follows:

3. Select the menu item **Interval** by pressing buttons ↑ and ↓, and confirm with button ✓.
4. Adjust the interval by pressing buttons ↑ and ↓, and confirm with button ✓.

If Recover IP has been activated, the IP address configuration can be carried out immediately. In order to do so, proceed as follows:

- Select the menu item **Recover now** by pressing buttons ↑ and ↓, and confirm with button ✓.



Note

If Recover IP is activated and no access to the Internet portal is possible, the datalogger will restart every 60 minutes.

4.5.8 Erase

In the **Erase** submenu, the following adjustments can be made:

- Erase data
- Reset

The menu item **Erase** can be used to erase all logged data from the internal memory of the DL3 Datalogger. In order to erase the data, proceed as follows:

1. Select the menu item **Erase data** by pressing buttons ↑ and ↓, and confirm with button ✓.
2. To erase all data, confirm the security enquiry **Erase?** by selecting **Yes** and confirming by pressing button ✓.

The menu item **Reset** can be used to erase all logged data from the internal memory of the DL3 Datalogger and to reset all adjustments made in the DL3 back to their factory settings.

To erase all data and reset all adjustments to their factory settings, proceed as follows:

1. Select the menu item **Reset** by pressing buttons ↑ and ↓, and confirm with button ✓.
2. To erase all data and reset all adjustments, confirm the security enquiry **Erase?** by selecting **Yes** and confirming by pressing button ✓.



Note

After a reset, the device has to be added to VBus.net again.

4.5.9 Version

In order to display the software version, proceed as follows:

- Select the menu item **Version** by pressing buttons ↑ and ↓, and confirm with button ✓.

The current software version is displayed.

4.6 LAN connector

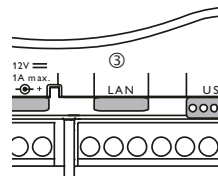

The integrated LAN connector ③ is located on the terminal strip of the device. The LAN connector supports transfer rates of up to 100 MBit per second.

4.7 USB interface

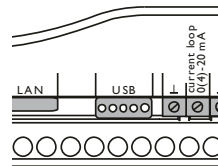

The DL3 is equipped with a USB interface to which the USB adapter cable can be connected.

In order to connect the USB adapter cable to the DL3, proceed as follows:

- Connect the USB adapter cable to the interface marked **USB**.



Note

Presently, the firmware of the device does not support external USB devices. As soon as USB support becomes possible, it will be made available via an automatic DL3 Datalogger firmware update.

Menu structure

Adjustment channel	Adjustment range/selection	Factory setting
Language	English, Deutsch, Français, Español, Italiano	
Date and time		
Time		
-Date	01.01.2001 ... 31.01.2050	
-Time	00:00 ... 23:59	
VBus		
-VBus 1 ... VBus 6	Yes, No	No
HQM		
-Activated	Yes, No	Yes
-Fluid type	Water, Propyl., Ethyl., Tyfo LS	Water
-Cencentr.	20 ... 70 %	37 %
-Reset	Yes, No	
Sensors		
-S1 ... S3		
-Type	None, Pt1000, Pt500, KTY, Impulse	None
-Offset	-15.0 ... +15.0 K	0.0 K
-Vol./Imp.	0.1 ... 100.0 l/Imp	1.0 l/Imp
-Current loop		
-Type	None, 0-20 mA, 4-20 mA, Si-420TC	
Logging		
-Interval	00:01 ... 20:00 (mm:ss)	
-Log. type	linear, cyclic	cyclic
Network		
-VBus.net	Yes, No	No
-LAN		
--Auto configuration	Yes, No	Yes
--Add.		
--Mask		
--Recover IP	Yes, No	No
--Interval	00:10 ... 24:00	
--Recover Now		

Adjustment channel	Adjustment range/selection	Factory setting
Erase		
-Erase data	Yes, No	No
-Reset	Yes, No	No
Version		

4.8 SD memory card slot

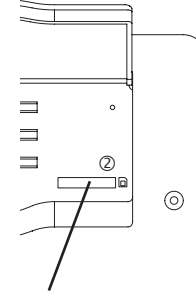

SD memory card slot

The SD memory card slot ② is located at the front of the device. By means of the SD memory card slot, logged data can be transferred onto an SD card.



Note

The memory of an SD card in the slot is used for data transfer only. It will not enlarge the memory of the DL3 Datalogger.

4.9 Power supply connection

Power supply is carried out via an external mains adapter. The connection terminals are located inside the housing of the DL3 Datalogger.

4.10 VBus® connection

The DL3 Datalogger is connected to one or several RESOL controllers via VBus® cables. The connection terminals are located inside the housing of the DL3 Datalogger.

5 Accessing the DL3 Datalogger over the Internet with the VBus.net visualisation portal

The DL3 Datalogger can be easily connected to VBus.net.

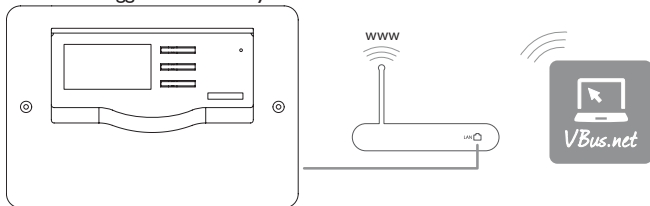

Note

In order to use VBus.net for accessing the DL3 Datalogger, Internet access has to be enabled.



Note

In order to enable VBus.net access, the Datalogger must have unconditional access to the ports 80 and 1194/1195.

In order to access a DL3 Datalogger via VBus.net, proceed as follows:

1. Activate VBus.net in the DL3.
2. Note down the alphanumeric 8-10-digit code (Access Token) indicated on the display of the DL3.
3. Enter VBus.net into the address bar of the browser and click **Sign up**.
4. Wait for the confirmation e-mail to arrive.
5. Click **Add new device**.
6. Enter the alphanumeric 8-10-digit code (Access Token).

In order to access the DL3 Datalogger over the Internet without VBus.net, see chap. 9.1 **Accessing the DL3 Datalogger over the Internet without VBus.net** on page 23.

6 Accessing the DL3 Datalogger with the RPT Parameterisation Tool via VBus.net

To use RPT, the **VBus access over local network** has to be enabled.

In order to activate the VBus access, proceed as follows:

1. In the main menu **Device Config**, select the submenu **Remote Access**.
2. On the **VBus access over local network** tab, in the dropdown menu **Local network access enabled?** select **Yes**.
3. On the **Remote access over Internet** tab, in the dropdown menu **Use VBus.net for remote access?** select **Yes**.

With a VBus.net account you can easily use RPT in order to parameterise the controller:

1. In the VBus.net menu **My Devices**, click on **Edit**.
2. On the **General settings** page, tick the option **Allow parameterization using the via address and the RESOL Parameterization Tool (RPT)**.
3. Enter the Via tag from the VBus.net menu item **General settings** into the RPT field **URL/IP**.
4. Enter the password into the **Password** field.
5. Click on **Connect**.

7 Web interface

The web interface is integrated in the DL3 Datalogger and can be run on an Internet browser.

The web interface has the following functions:

- Display the status of the DL3 Datalogger.
- Configure the Datalogger DL3.
- Display real-time data in a table.
- Export, customise and erase data.

7.1 Menu

The menu column with all main menus and their corresponding submenus are indicated on the left-hand side of the web interface.



Note

The menu structure may change in later firmware versions.

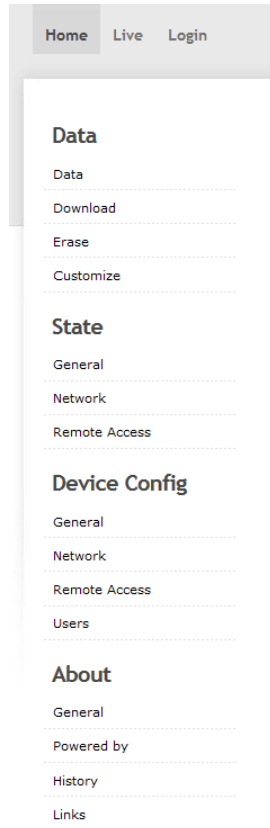

The menu bar at the top of the web interface contains the menu items **Home**, **Live** (see below) and **Login**.

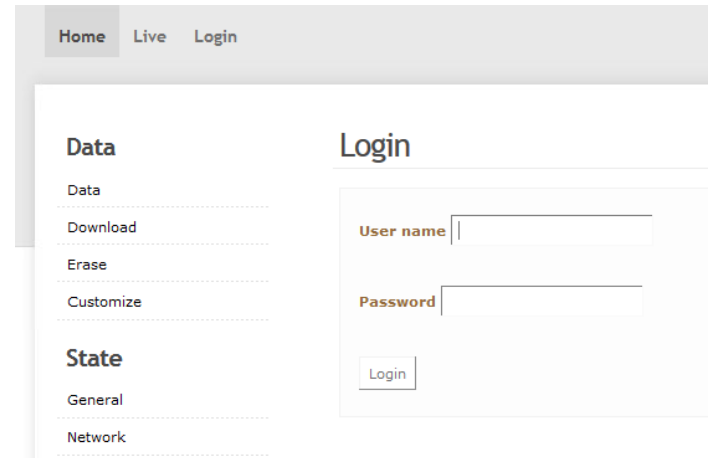

In order to use the web interface to its full extent, login is required. In order to log in, proceed as follows:

1. Click **Login** on the menu bar.
2. Enter the user name in the **User name** input field.
3. Enter the password in the **Password** input field.
4. Click the **Login** button.

The message **Login successful!** appears.

7.2 Menu overview

Main menu	Submenu	Function
Data	Data	The display of data varies depending on the adjustments
	Download	Export data
	Erase	Erase data
	Customize	Configuring the live data display Uploading a customised view of the live data Downloading a customised view of the live data Resetting the live data display adjustments
State	General	Display general device information
	Network	Display network configuration
	Remote Access	Display remote access configuration
Device Config	General	Change general configuration
		Change logging configuration
		Change date and time configuration
		Change firmware update configuration
	Network	Network configuration
		Change FTP configuration
		SSH configuration
Remote access	Change the remote access password	
	Configure remote access over Internet	
	Configure BACnet access	
Users	Changing the user password	
About	General	Order DL3 Datalogger open source software
	Powered by	Display of the open source applications and libraries used
	History	Display of firmware updates
	Links	Useful links

7.3 Data

In the live data display, the values of the controllers connected and of the internal DL3 sensors are displayed and refreshed automatically every 10 seconds. The representation and the measurement units of the live data can be customised individually.

Live data of controllers connected and internal DL3 sensors can be displayed as follows:

- In a tabular overview
- In a schematic drawing of the solar system

Displaying data in a tabular overview

In this menu, a selection can be made whether to display all live data, internal DL3 data or data of a controller connected.

In order to display all live data in a tabular overview, proceed as follows:

➔ In the main menu **Data**, submenu **Data**, select **All live data**.

In order to display the internal DL3 data in a tabular overview, proceed as follows:

➔ In the main menu **Data**, submenu **Data**, select **DL3 internal**.

If one or several controllers are connected, they are indicated and can be selected.

In order to display the data of a controller connected in a tabular overview, proceed as follows:

➔ In the main menu **Data**, submenu **Data**, select the corresponding controller.

7.4 Erasing logged data

Logged data can be erased over the web interface or over the menu. The configuration is not affected.

Erase logged data over the web interface

In order to erase logged data, proceed as follows:

1. In the main menu **Data**, select the submenu **Erase**.
2. Click the **Erase** button.

The message **Data erased successfully!** appears.

Erase logged data over the menu

See chap. 4.5.8 **Erase** on page 14.

7.5 Displaying firmware versions

In order to display statistics about the firmware update run, proceed as follows:

➔ In the main menu **About**, select the submenu **General**.

The following information is displayed:

- Firmware update version
- Firmware update date

 See chap. 8.7 **Configuring automatic firmware update configuration** on page 21.

7.6 Displaying the Device Date/Time

In order to display the device date and the device time, proceed as follows:

➔ In the main menu **Status**, select the submenu **General**.

The following information is displayed:

- Current date and time settings of the DL3
- Device uptime since the last reset

 See chap. 8.6 **Configuring date and time information** on page 21.

7.7 Displaying network configuration

In order to display the network configuration, proceed as follows:

➔ In the main menu **Status**, select the submenu **Network**.

The following information is displayed:

- LAN IP address
- LAN network/netmask
- Gateway
- Nameserver 1
- Nameserver 2

 See chap. 9.5 **Network configuration** on page 27.

7.8 Displaying data communication

In order to display statistics about the data exchange between the DL3 Datalogger and the controllers connected, proceed as follows:

➔ In the main menu **Status**, select the submenu **General**.

The following information is displayed:

- Total received bytes count since last reset
- Total received packet count since last reset
- Total unique packet count since last reset

7.9 Displaying the memory capacity

In order to display the memory capacity, proceed as follows:

➔ In the main menu **Status**, select the submenu **General**.

The following information is displayed:

- Capacity in use
- Capacity free
- Remaining days

 **Note**
The log interval determines the **Remaining days**. Depending on the adjustment selected, the logging either stops when the capacity is fully used or the oldest data are overwritten.

 See chap. 9.3 **Log interval configuration** on page 27.

7.10 Displaying the remote access

In order to display the status of the remote access, proceed as follows:

➔ In the main menu **Status**, select the submenu **Remote access**.

On the **Remote access** tab, the status of **Local network access enabled?** is displayed.

On the **Remote access over Internet** tab, the status of **Use VBus.net for remote access?** is displayed.

8 Basic configuration

In order to carry out the basic configuration, proceed as follows:

1. Find the DL3 Datalogger by means of the DeviceDiscoveryTool
2. Change the web interface language
3. Change the live data display language
4. Change the user password
5. Change the device name
6. Change the time configuration
7. Configure the automatic firmware update configuration
8. Change the remote access password

8.1 Finding the DL3 Datalogger by means of the DeviceDiscoveryTool

The DeviceDiscoveryTool is a software that displays Dataloggers that are connected directly or via the local network.



Note

The factory setting for both user name and password is **admin**.



Note

Starting the DeviceDiscoveryTool from the CD is possible under a Windows operating system only.

To start the DeviceDiscoveryTool, Java (version 6 or higher) must be installed on the computer.

Starting the DeviceDiscoveryTool from the included CD

In order to start the DeviceDiscoveryTool from the included CD, proceed as follows:

1. Open the **DL DiscoverTool** folder.
2. Start **DLDiscoverToolSetup.exe**.
3. Confirm all following dialogues with **OK**.
4. Click **Start/Programs/RESOL/DeviceDiscoveryTool/ DeviceDiscoveryTool**.

All DL3 Dataloggers found are displayed.

5. Click the DL3 Datalogger to mark it.

6. Click **Open**.

A new window opens.

7. Enter user name and password.

The Home screen of the DL3 web interface opens.

8.2 Changing the web interface language

The web interface can be run in different languages.

➔ Click one of the small flags on the right-hand side of the Home screen, according to the desired language:

- German
- English
- French
- Spanish
- Italian

The message **Language selection successful!** appears.

8.3 Changing the live data display language

In order to select the language of the live data display, proceed as follows:

1. In the main menu **Device Config**, select the submenu **General**.
2. On the **General Configuration** tab, in the dropdown menu **Default Language**, select one of the following languages:

- Deutsch (de)
- English (en)
- Français (fr)
- Español (es)
- Italiano (it)

3. Click **Save configuration**.

The message **Configuration saved successfully!** appears.

8.4 Changing the user password

In order to change the user password, proceed as follows:

1. In the main menu **Device Config**, select the submenu **Users**.
2. Select the desired user.

The tab for the user selected opens.

3. Tick the **Change password** checkbox.

4. Enter the current password into the **Current password** input field.

The factory setting for the password is **admin**.

5. Enter the new password into the **New password** input field.

6. Enter the new password into the **Repeat new password** input field.

7. Click **Save configuration**.

The **Login** window opens.

8. Enter the user name and the new password.

The message **Configuration saved successfully!** appears.

8.5 Changing the device name



Note

Choose a descriptive device name to facilitate identifying the DL3 Datalogger in the network.

In order to change the device name, proceed as follows:

1. In the main menu **Device Config**, select the submenu **General**.
2. On the **General Configuration** tab, enter the device name in the **Device Name** input field.

Permitted characters are: letters, numbers, underscores.

- In the **Default Language** dropdown menu, select the desired language.
- Click **Save configuration**.

The message **Configuration saved successfully!** appears.

8.6 Configuring date and time information

The **Date and Time Configuration** determines where the DL3 Datalogger obtains its date and time information.

The Date and Time Configuration can be set to the following adjustments:

- Automatic (recommended): Date and time information are automatically synchronised between the DL3 Datalogger and the NTP server.
- Manual: The user manually assigns date and time information to the DL3 Datalogger.

Synchronising time information automatically

In order to automatically synchronise time information, proceed as follows:

- In the main menu **Device Config**, select the submenu **General**.
- On the **Date and Time Configuration** tab, in the **Time Zone** dropdown menu, select the desired time zone.
- In the **NTP synchronisation enabled?** dropdown menu, select **Yes**.
- Enter the NTP server address.

Factory setting: eu.pool.ntp.org.

- Click **Save configuration**.

The message **Configuration saved successfully!** appears.

Assigning time information manually

In order to manually assign the time information, proceed as follows:

- In the main menu **Device Config**, select the submenu **General**.
- On the **Date and Time Configuration** tab, tick the **Manually set time to** checkbox.
- Enter time information (day, month, year, hours, seconds).
- Click **Save configuration**.

The message **Configuration saved successfully!** appears.

8.7 Configuring automatic firmware update configuration

The firmware is the internal software of the DL3 Datalogger. Through firmware updates, the software will be improved in the following ways:

- Extended functional range
- Enhanced operation
- Customisation of the web interface desktop

When automatic firmware updates are enabled (strongly recommended), the DL3 Datalogger will search for new firmware versions in regular intervals.



Note

Previous configurations are not affected by a firmware update.



Note

When there is no Internet connection, firmware updates can only be run with an SD card.



See chap. 10 **Firmware update with SD card** on page 30.

In order to configure firmware updates, proceed as follows:

- In the main menu **Device Config**, select the submenu **General**.
- On the **Firmware update** tab, in the **Automatic update query enabled?** input field, select **Yes**.
- Enter the **Update URL**.

Factory setting: <http://www.vbus.net/api/update>.

- Click **Save configuration**.

The message **Configuration saved successfully!** will appear.



Note

Only change the firmware update URL if required, and consult the system administrator before doing so!

If a firmware update is available, it will be displayed after the login in the **Login successful** window.

- Click on **Click here to proceed**.
- In order to start the update process, click on **Click here to download**. The update file will be downloaded.
- Unzip the file.
- In order to install the update, click on **Upload**.
- Select the upload file **firmware.cbor** and click on **open**.

The update file will be loaded.

- ➔ In order to run the update, click on **Install update**.
- ➔ If you do not wish to run the update, click on **Discard update**.

If the update has been installed, the device will restart.

If the automatic update query has been deactivated, you can query for updates manually.

1. In the main menu **Configuration**, select the submenu **General**.
2. On the **Firmware update** tab, click on **Query for updates now**.
Updates available will be displayed under **Firmware**.

8.8 Carrying out a VBus® specification update

In order to make sure that the controller connected can be recognised and read out to its full functional extent, VBus® specification updates are made available on the Internet.

The update can be carried out over the Internet or via a computer connected to the device.

If the device is connected to the Internet, it will find and upload the update files automatically.

1. In order to carry out the update, click **Install update**.

VBus specification

Version currently installed 20 (20190730)

Version available 30 (20200622) **Install update**

2. In order to carry out the update, confirm the following dialogue by clicking Yes.

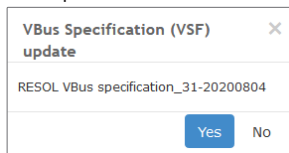

When the update has been installed, the device restarts. It is necessary to log in again.

An update can also be installed via a computer connected to the device.

In order to carry out the update, proceed as follows:

1. Download the **vbus_specification.cbor** file onto the computer.
2. In order to upload the update file, click on **Upload**.
3. Select the update file and confirm the selection.

After the upload has been completed, the update file appears in the Web interface.

VBus specification

Version currently installed 20 (20190730)

Version available 30 (20200622) **Install update**

Upload update file

Version uploaded 10 (20180524) **Install update** **Discard update**

4. In order to start the update, click **Install update**.

When the update has been installed, the device restarts. It is necessary to log in again.

If no update is to be carried out, click **Discard update**.

8.9 Configuring the remote access

ATTENTION! Third-party access!



When the default remote access password is not changed, third parties may gain unauthorised access to the controller connected.

→ **Do change the remote access password, note it down and keep it in a suitable place.**

The remote access password is required whenever a controller connected to the DL3 Datalogger is to be accessed via the RESOL RPT Parameterisation Tool.



Note

For older controller models the RESOL ServiceCenter Software is available!

In order to change the remote access password, proceed as follows:

1. In the main menu **Device Config**, select the submenu **Remote Access**.
2. On the **Access VBus over local network** tab, tick the **Change password** checkbox.
3. Enter the current password into the **Current password** input field.

The factory setting for the remote access password is **vbus**.

4. Enter the new password into the **New password** input field.
5. Enter the new password into the **Repeat new password** input field.
6. Click **Save configuration**.

The message **Configuration saved successfully!** appears.

9 Advanced configuration

9.1 Accessing the DL3 Datalogger over the Internet without VBus.net



Note

The DeviceDiscoveryTool cannot be used for finding a DL3 Datalogger over the Internet.

The following preparations have to be made when a DL3 Datalogger connected to the Internet via a router is to be accessed over the Internet:

- Assign a static address to the router.
- Carry out port routing in the router.

Assigning a static router address

In order to access the router and the DL3 connected over the Internet, a static address has to be assigned to the router.

There are 2 different ways to assign a static Internet address to the router:

- Over a dynamic Domain Name Server (DynDNS)
- Over a static Internet IP address

Using a dynamic Domain Name Server (DynDNS)

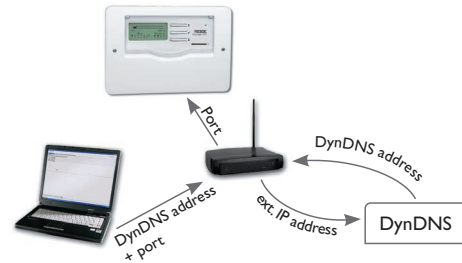

Schematic representation: Remote access to the DL3, router with DynDNS address.



Note

Not all routers support DynDNS services. For further information consult the router documentation.

It is possible to reserve an Internet address via a DynDNS service provider. DynDNS services are usually free of charge.

Schematic process representation of using a DynDNS address:

1. Open an account for a DynDNS Internet address at a DynDNS service provider. A DynDNS Internet address and the corresponding access information will be provided.
2. The DynDNS access information has to be entered into the router, so that the router can tell the DynDNS service provider where to route enquiries to.
3. In order to access the router via the Internet, the user has to enter the DynDNS Internet address into the Internet browser.

Using a static Internet IP address



Schematic representation: Remote access to the DL3, router with static Internet IP address.

It is possible to apply for a static Internet IP address at an Internet Service Provider (ISP). For a static IP address, there usually is a fee required.

Schematic process representation of using a static IP address:

1. Apply for a static IP address at an Internet Service Provider (ISP). A static Internet address and the corresponding access information will be provided.
2. The access information has to be entered into the router, so that the router can register at the ISP with the static IP address.
3. The router registers at the ISP with the static IP address.
4. In order to access the router via the Internet, the user has to enter the static Internet address into the Internet browser.

Port routing in the router



Note

Not all routers support port routing. For further information consult the router documentation.

In order to access, over the Internet, one or several Dataloggers connected to one router, port routing has to be configured in the router.

The DL3 Datalogger communicates via the following ports:

- Web interface port: **443** (adjustable, default port: 443)
- RESOL RPT Parameterisation Tool/RESOL ServiceCenter port: **7053** (non-adjustable)
- BACnet port: 47808 (non-adjustable)

In order to carry out port routing in the router, proceed as follows:

1. Assign a static LAN IP address to the DL3 Datalogger using the configuration menu of the router.
2. Assign a port to the IP address menu using the configuration menu of the router.

Example: Port routing

Datalogger number	DynDNS address	Port routing from port:	Port routing to port:	DL3 LAN IP
1	www.Datalogger.ath.cx:443	443	443	192.168.0.10
2	www.Datalogger.ath.cx:444	444	443	192.168.0.11
3	www.Datalogger.ath.cx:445	445	443	192.168.0.12
1	www.Datalogger.ath.cx:7053	7053	7053	192.168.0.10
2	www.Datalogger.ath.cx:7054	7054	7053	192.168.0.11
3	www.Datalogger.ath.cx:7055	7055	7053	192.168.0.12

In this example (see table below), 3 DL3 Dataloggers are assigned 1 web interface port and 1 RESOL ServiceCenter software port each.

9.2 BACnet access

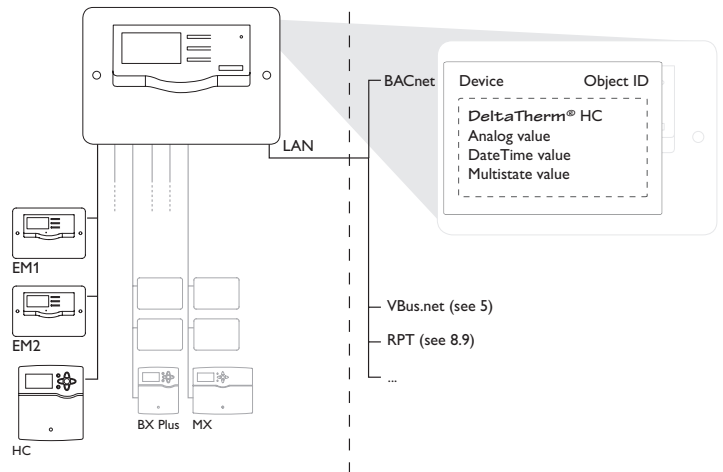

The following preparations have to be made in order to access the DL3 Datalogger over BACnet.

1. Connect the DL3 Datalogger to the LAN network.
2. Connect the devices to the DL3 by means of the VBus® and establish the power supply.

To each VBus® connection, 1 controller can be connected.

3. In the main menu **Data**, select the submenu **Data**.
4. In the **Live Views** check if all devices connected are available at the corresponding VBus® connections.
5. Activate and configure the BACnet access in the Web interface of the DL3 Datalogger.
6. In the main menu **Device Config**, select the submenu **Remote Access**.
7. On the **BACnet access** ① tab, select **Yes** in the **Enable BACnet access?** ② field.
8. Enter the BACnet-Device-Object-ID in the **BACnet address** field ③.

The BACnet-Device-Object-ID is provided by the person using or designing the building management system.

9. Click **Save configuration**.

The message **Configuration saved successfully!** appears.

- ➔ In order to get back to BACnet configuration, click **Back to configuration** and select the **BACnet access** tab.

Configuration: Remote Access

Access VBus over local network

Remote access over internet

BACnet access ①

Enable BACnet access? Yes ②

BACnet address 70538 ③

Save configuration

Show list of assigned BACnet IDs

EDE file
Multistate values



Note

BACnet uses port 0xBAC0 (47808).



Note

Do not change the allocation of the VBus® connections after BACnet access has been activated. BACnet retains the previous configuration. If the allocation is changed, the device has to be reset to its factory settings (see page 14).



Note

The BACnet configuration can only be set back to its factory settings by resetting the device (see page 14).

Read access

The VBus® data will be transformed into objects for use in the BACnet network.

1. In the main menu **Device Config**, select the submenu **Remote Access**.
2. Select the **BACnet access** tab and click on **Show list of assigned BACnet IDs**.

A dialogue will appear in which the VBus® data can be transformed into and issued as BACnet analog inputs.

3. Enter the BACnet network name of the device into the **Device name** field ①.
4. Enter the device description for the BACnet network into the **Device description** field ②.

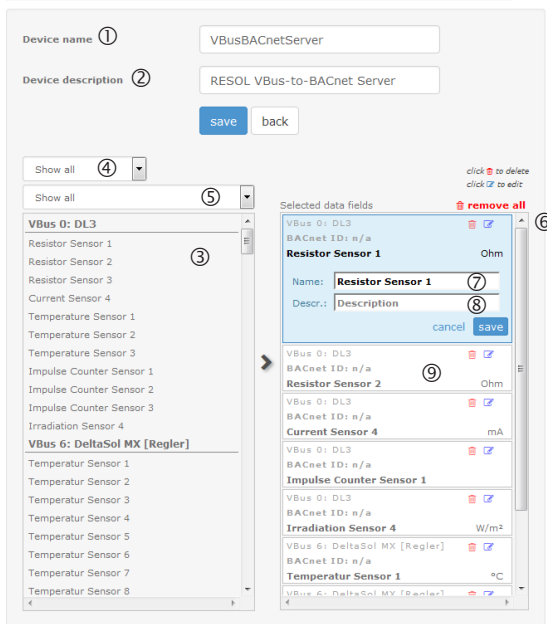

VBus® data available will be listed in the left-hand window ③.

2 filters can be used for the VBus® data display.

The upper filter ④ allows for filtering out the following value types:

- **Show all:** Displays all value types
- **Temperature:** Displays temperature values
- **VolumeFlow:** Displays flow rate values
- **Time:** Displays time values
- **Energy:** Displays energy values

The lower filter ⑤ allows for filtering out VBus® data of devices connected according to the individual VBus® connections:

- **Show all:** Displays all channels
- **VBus® x:** Displays VBus® data of the device connected to the corresponding connection.

The analog inputs generated from the VBus® data will be listed in the right-hand window (**Selected data fields** ⑥).

In order to transform VBus® data into analog inputs for the BACnet network, proceed as follows:

1. In the upper **Show all** field ④, enter the value types to be displayed.
2. In the lower **Show all** field ⑤, select the BACnet network devices desired.
3. Select the desired value in the left-hand window ③ and click on the arrow.

It will appear in the right-hand window **Selected data fields** ⑥.

When generating BACnet analog inputs, the names of the VBus® data points will be adopted automatically.



Note

In order to transform several values at once into analog inputs, hold down the Ctrl key (Mac: CMD key), select the desired values in the left-hand window ③ and click on the arrow.

4. In order to edit the display of a VBus® data point as a BACnet analog input, click on the corresponding value in the **Selected data fields** field and then on the  symbol.

In the **Name** field ⑦, a name can be entered, a description can be entered into the **Descr.** Field ⑧.

5. In order to save the changes, click on **save**.



Note

The DL3 Datalogger will automatically assign a **BACnet-ID** ⑨ to the analog input. It will be displayed instead of **n/a** when the changes have been saved.

6. Wait until the save process is completed (**save** will then no longer be greyed) before continuing to edit.
7. In order to delete a BACnet analog input selected, click on the corresponding value and then on the  symbol.
8. In order to delete all analog inputs, click on **remove all**.
9. In order to save the changes, click on **save**.
10. In order to get back to the **BACnet access** tab, click on **back**.
11. In order to download an EDE file for the current DL3 BACnet configuration, click on **EDE file**.



Note

During the whole BACnet configuration process and the download of the EDE file, the devices have to be connected to the DL3 Datalogger over the VBus®.

12. In order to download a Multistate values list matching the EDE file, click on **Multistate values**.

9.3 Log interval configuration

In order to configure the log interval, proceed as follows:

1. In the main menu **Device Config**, select the submenu **General**.
2. On the **Logging Configuration** tab, in the **Log interval** input field, enter the desired value.
3. Click **Save configuration**.

The message **Configuration saved successfully!** appears.

Capacity: 160 MB

Example: Log interval

Log interval	1 DeltaSol® MX	1 DeltaSol® MX, 1 EM, 1 heating circuit activated	1 DeltaSol® MX, 3 EM, 3 heating circuits activated, 1 HQM activated
75 s	7 months	6 months	4 months
150 s	15 months	12 months	9 months
300 s	30 months	24 months	18 months

The log interval determines the frequency in which the DL3 Datalogger logs data.



Note

Log intervals between 1 second and 86400 seconds (24 hours) are possible.



Note

The smaller the log interval, the more memory capacity is used.

9.4 Log mode configuration

The log mode determines how the DL3 Datalogger behaves when its internal memory capacity is fully used.

There are 2 different settings possible for the log mode configuration:

- Cyclic logging (factory setting): When the memory capacity is fully used, the oldest data will be overwritten.
- Linear logging: When the memory capacity is fully used, data logging stops.

In order to configure the log mode, proceed as follows:

1. In the main menu **Device Config**, select the submenu **General**.
2. On the **Logging Configuration** tab, in the **Log mode** dropdown menu, select the desired value.
3. Click **Save configuration**.

The message **Configuration saved successfully!** appears.

9.5 Network configuration

The network configuration determines where the DL3 Datalogger obtains its IP information.

There are 2 different settings possible for the network configuration:

- Dynamic (recommended): The IP information is automatically assigned to the DL3 Datalogger by the DHCP server.
- Static: The user manually assigns IP information to the DL3 Datalogger.



Note

Consult the system administrator before changing the factory settings!

In order to configure the network configuration, proceed as follows:

1. In the main menu **Device Config**, select the submenu **Network**.
2. In the **LAN configuration mode** dropdown menu, select the desired value.
3. Click **Save configuration**.

The message **Configuration saved successfully!** appears.

9.6 Data display configuration

Live Data

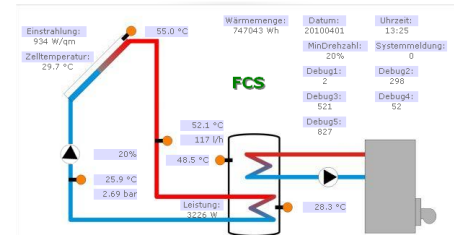

Example of a live data display

The DL3 Datalogger displays live data of the controller connected. In the tabular overview, the data are refreshed automatically every 10 seconds.

The data can be displayed as follows:

- In a schematic drawing of the system in which sensor data are assigned to the components.
- In a tabular overview (factory setting).

In order to reduce the data traffic from the local network to the Internet, the background drawing of the system can optionally be stored on an Internet server.

Requirements for the display of live data in a schematic drawing of the system

The following requirements must be met in order to display live data (of a controller connected) in a schematic drawing of the system:

- A schematic drawing of the system must be created using a drawing program (e.g. Inkscape or GraphicWorks).
- The schematic drawing must be supplied in one of the following formats: *.jpg, *.gif, *.png, *.bmp, *.tif.
- The RESOL ServiceCenter software must be installed on the computer.
- The FTP access to the DL3 Datalogger must be enabled.

 See chap. 12 **FTP access configuration** on page 31.

The address and the port of the DL3 Datalogger must be on hand.

 See chap. 9.3 **Log interval configuration** on page 27.

Uploading a system drawing

In order to upload a system drawing into the web interface of the DL3 Datalogger, proceed as follows:

1. Start the RESOL ServiceCenter software.
2. In the main menu **Window**, select the submenu **Show view -> VBus® logging**.
3. Click the **Designer** tab.
4. Right-click the empty graphic (white square) and select **Edit**.
5. Select **Use background image** and click the [...] button to the right.
6. Select the drawing prepared as a background image and click **Open**.
7. Click **OK**.
8. Click **Connect**.
9. Select the DL3 Datalogger and enter the remote access password.
10. Right-click the system drawing and select **Add → Add VBus® field**.

The **Add VBus field** menu opens.

11. Select the menu item **Total received packet count**, click the desired **VBus® field** and confirm by clicking **OK**.

The field is added to the system drawing. When the mouse is moved over the field, field information are displayed.

12. Place the field in the desired position using the left mouse button.
13. When all VBus® fields have been placed, click **Export to DL3**.

The **Export designer document to DL3** window opens.

14. Enter the IP address of the DL3 Datalogger into the **DL3 host name** field.
15. Enter the user name into the **DL3 user name** field.
16. Enter the user password into the **DL3 user password** field.
17. Save the background image.
 - In order to store the background image on the DL3 Datalogger (recommended), click the **USE DL3 FTP Server to store background graphics** field.
 - In order to store the background image on an Internet server, click the **Use custom URL to access background graphics** field.
18. Click **OK**.

A window opens to indicate that the export has been completed successfully. The web interface automatically opens and displays the system drawing. The upload process has been completed.

Configuring the units for the live data display

The DL3 Datalogger can display live data in different units. The desired units can be selected from dropdown menus.



Note

Some controllers transmit sensor signals in degrees Fahrenheit over the VBus® although temperatures are in fact measured in degrees Centigrade. The **Convert to °F** option can be used to correct this display error. The numerical values are not changed.



For a detailed overview of the conversion factors used, see chap. 16.2 **Unit conversion table** on page 34.

In order to adjust the units of the live data, proceed as follows:

1. In the main menu **Data**, select the submenu **Customize**.
2. Select the desired format in all dropdown menus.
3. Click the **Create** field.

Depending on the Internet browser used, a new tab or window opens.

4. Save the template in the HTML format.
5. Go back to the DL3 web interface.
6. In the main menu **Data**, select the submenu **Customize**.
7. Click **Browse**.
8. Select the template created.
9. Click **Upload**.
10. Click **OK**.

The message **Customize: Upload successful!** appears.

Advanced customization of the data display

The user interface of the data display can be adapted to specific requirements by an advanced customization.

By editing the user interface with an HTML editor, the page design, the field names, the font etc. can be changed.



Note

For advanced data customization, HTML knowledge and using an HTML editor are required.

In order to configure the data display, proceed as follows:

→ In the main menu **Data**, select the submenu **Customize**.

The following adjustments are available:

- In the **Create a new customized view** submenu, new views can be created.

→ Click the **Create** field.

- In the **Upload the customized view** submenu, views can be uploaded.

- In the **Download the customized view** submenu, views can be downloaded.

In order to upload or download a Customized view, proceed as follows:

1. Save the page in the HTML format.

The file name must end in *.htm, e.g. template.htm.

2. Open the template in an HTML editor.

3. Make the desired changes and save the file.

4. Click **Browse**.

5. Select the template created.

6. Click **Upload**.

The template will be loaded into the Datalogger and the live data will be displayed in the image created.

9.7 Filter configuration

The filter determines which data are to be displayed.

An existing filter can be edited or a new filter can be created.

In order to create a new filter, proceed as follows:

1. In the main menu **Data**, select the submenu **Customize**.

2. Click the **Create a new filter** tab.

3. In the **Filter Number** dropdown menu, select the **Filter slot**.

4. Enter the desired filter name into the **Filter Name** field.

5. In the **Filter Channels** dropdown menu, select the desired data items.

6. Click **Create**.

A view of the data filter appears.

1. In order to make the filtered data visible to guests, tick the **Visible to guests?** checkbox.

2. In order to create a link to the filter, select the desired value in the **Put a link to this filter into** dropdown menu.

3. Tick the checkboxes of the desired values and enter the desired names into the name fields.

4. Click **Update filter**.

In order to edit an existing filter, proceed as follows:

1. In the main menu **Data**, select the submenu **Customize**.

2. Click the **Edit an existing filter** tab.

3. Select the desired filter and click **Edit**.

A view of the data filter appears.

4. Edit the filter as described before.

5. Click **Update filter**.

9.8 Public access configuration

ATTENTION! Data loss!



If the public access includes access to the **Erase data** menu, unauthorised third parties can erase data stored in the Datalogger.

→ In order to prevent unauthorised data erasure, do not enable public access to the **Erase data** menu!

The public access configuration determines which DL3 Datalogger menus unregistered users may access.

The factory setting for the public access configuration does not enable menu access.

In order to configure the public access to the menus, proceed as follows:

1. In the main menu **Device Config**, select the submenu **Users**.
2. In the submenu **Users**, click the user name guest.
3. In the dropdown menus, select the desired value.
4. Click **Save configuration**.

The message **Configuration saved successfully!** appears.

Dropdown menu	Functions
Home	Display Home screen
Status	Display device status Display memory capacity
Data - Live	Display live data
Data - Download	Export data over the web interface
Data - Erase	Erase logged data over the web interface
About DL3	Order DL3 Datalogger open source software Display firmware versions

Overview of menus configurable for public access.

10 Firmware update with SD card

New firmware versions extend the functional range and enhance the operation. The current software can be downloaded from www.resol.de/firmware.

In order to run a firmware update over the SD card slot, proceed as follows:

1. Download the firmware from the Internet (www.resol.de/firmware) and save it to your PC.
2. Extract the file.

Among the extracted files there is a folder called **SDCARD**.

3. Insert an SD card formatted with the FAT32 format into the PC.
4. Copy the contents of the **SDCARD** folder onto the first level of the SD card.

There should then be a folder structure called RESOL/DL3 on the SD card, containing the firmware file.

5. Remove the SD card from the PC and insert it into the SD card slot of the DL3.

The operating control LED starts flashing green.

The message **Do not remove SD card!** appears.

6. Wait until the operating control LED is permanently green.

The menu item **Update** appears.

7. Select **Update** and confirm with **Yes**.

The operating control LED starts flashing green and then red/green.

The message **Restarting device** appears.

The operating control LED starts flashing green.

The message **Do not remove SD card!** appears.

When the firmware update is completed, the menu item **Copy data** appears.

11 Data export

There are 2 different ways to export logged data from the DL3 Datalogger:

- Export logged data onto an SD memory card. The data are stored as a VBus® format file and can be read out on a computer using the RESOL ServiceCenter software.
- Export logged data onto a computer over the web interface. Different file formats can be selected.



Note

Information about exporting data over the Web interface can be found in the detailed manual on the CD included.

11.1 Data export over SD card

In order to copy data onto an SD card, proceed as follows:

- Insert the SD card into the SD card slot

The operating control LED flashes (green):

The card has been recognised and data are being transferred.

The operating control LED is permanently green:

The transfer is completed. The card can be removed.

11.2 Data export over web interface



Note

The internal processor of the DL3 Datalogger needs up to 30 minutes to convert logged data. If the data are required in a text format (tab separated, Windows), the data can alternatively be exported onto a computer using the VBus® protocol format. Then the data can be converted into a text format (tab separated, Windows) more quickly.



For an overview of file formats available in the web interface see chap. 16.1 **Possible export file formats** on page 33.



Note

Information about further processing transferred data are described in the RESOL ServiceCenter software manual.

In order to copy logged data onto a computer, proceed as follows:

1. In the main menu **Data**, select the submenu **Download**.
2. In the **File format** dropdown menu, select the desired format.
3. Click **Start download**.
4. Save the file in a folder of choice.

12 FTP access configuration

The following requirements have to be met in order to upload or download data to and from the DL3 Datalogger by means of an FTP client software:

- The FTP password has to be on hand.
- FTP access must be enabled.

In order to configure the FTP access, proceed as follows:

1. In the main menu **Device Config**, select the submenu **Network**.
2. On the **FTP Configuration** tab, in the **FTP server enabled?** input field, select **Yes**.
3. Tick the **Change FTP password?** checkbox.
4. Enter the current password into the **Current FTP password** input field.

Factory setting: **ftp**

5. Enter the new password into the **New FTP password** input field.
6. Enter the new password into the **Repeat new FTP password** input field.
7. Click **Save configuration**.

The message **Configuration saved successfully!** appears.

13 SSH configuration

The SSH configuration can be used for accessing the operating system of the DL3 Datalogger.

ATTENTION! Damage through incorrect configuration!



The SSH configuration requires detailed knowledge in the area of Linux administration. Incorrect configuration causes damage to the operating system of the DL3.

→ **SSH configuration may only be carried out by a specialised Linux administrator, and only if required.**

In order to activate the SSH access, proceed as follows:

1. In the main menu **Device Config**, select the submenu **Network**.
2. On the **SSH configuration** tab, in the **SSH access enabled?** input field, click **Yes**.
3. Tick the **Change SSH password?** checkbox.
4. Enter the current password into the **Current SSH password** input field. Factory setting: no password (empty field).
5. Enter the new password into the **New SSH password** input field.
6. Enter the new password into the **Repeat new SSH password** input field.
7. Click **Save configuration**.



The message **Configuration saved successfully!** appears.

14 Eliminating errors

Problems with the direct connection to a gigabit network device

Problem	Solution
When a device is connected directly to the DL3 Datalogger using a gigabit network adapter, no network connection is established.	 Note Not all network interface cards support 10 MBits/s half-duplex communication. <ul style="list-style-type: none">→ Alternative A: Interconnect a 100 MBits switch between the two devices.→ Alternative B: Set the network connection settings of your computer to 10 MBits/s half-duplex.

User password not available

Problem	Solution
The user password is not available.	When the user password is not available, the DL3 Datalogger has to be reset to its factory settings in order to regain access to the web interface.  Note When the DL3 Datalogger is reset to its factory settings, all logged data and the configuration will be erased. In order to save the logged data, they can be exported onto an SD card before a reset. After a reset, the device has to be added to VBus.net again.  See chap. 11.1 Data export over SD card on page 30.

The DL3 Datalogger is not found by the DeviceDiscoveryTool

Problem	Solution
The DL3 Datalogger is not found by the DeviceDiscoveryTool.	Check the following points in order to find and eliminate the error: <ul style="list-style-type: none">→ Check if the power supply to the DL3 Datalogger is established.→ Check if the network cable is properly connected at both ends!→ Check if the firewall software of the computer inhibits the connection to the DL3 Datalogger.→ Switch off the firewall software and use the DeviceDiscoveryTool to find the DL3 Datalogger.→ When the DL3 Datalogger has been found, the firewall software has to be reconfigured.→ Activate the firewall software!→ Check if the current Java software is installed. If no or an old Java version is installed, an error message appears. In order to eliminate the error, the current Java software has to be installed from http://java.com . <ul style="list-style-type: none">→ Check if an IP address is assigned to the DL3 Datalogger. An IP address has to be assigned to the Datalogger by a router or a directly connected PC. This process may take several minutes. Computers with a Windows operating system indicate an IP assignment in progress by displaying a symbol on the task bar. The symbol consists of two computers orbited by a yellow ball. <ul style="list-style-type: none">→ Check if an IP address is automatically assigned to the computer upon a direct connection to the Datalogger.

15 Ordering software

For an expense allowance of EUR 20,-, a DVD containing the source code and the compiler scripts of the Open Source applications and libraries can be ordered.

Please send your order to:

RESOL – Elektronische Regelungen GmbH

Heiskampstraße 10

45527 Hattingen

GERMANY

Please name the version number of the firmware in your order. It can be found in the web interface, main menu About, submenu **General**, bottom area (e. g.: „1.0 (200805241128)“). Per order, only one version number can be named.

16 Appendix

16.1 Possible export file formats

File format	Description
Text (tab-separated, Windows)	<ul style="list-style-type: none">Text file, optimised for being processed under Windows.Data are separated by a tabulator.
Text (CSV, Windows)	<ul style="list-style-type: none">Text file, optimised for being processed under Windows.Data are separated by a semicolon.
Text (tab-separated, Linux)	<ul style="list-style-type: none">Text file, optimised for being processed under Linux or Mac OSX.Data are separated by a tabulator.
Text (CSV, Linux)	<ul style="list-style-type: none">Text file, optimised for being processed under Linux or Mac OSX.Data are separated by a semicolon.
Excel	<ul style="list-style-type: none">XLS file, optimised for processing in a spreadsheet program compatible with MS Excel.A maximum of 65.535 data sets can be exported.
VBus® protocol data	<ul style="list-style-type: none">VBus® file, optimised for processing in the RESOL ServiceCenter software.

Export file formats available in the web interface.

16.2 Unit conversion table

Unit	BTU	MBTU	MMBTU
1 Wh	3.412128	0.003412	0.000003
1KWh	3412.128	3.412128	0.003412
1MWh	3412128	3412.128	3.412128

Unit	g CO ₂ _OIL	kg CO ₂ _OIL	t CO ₂ _OIL
1 Wh	0.568	0.000568	5,68 * 10 ⁻⁷
1KWh	568	0.568	0.000568
1MWh	568000	568	0.568

Unit	g CO ₂ _GAS	kg CO ₂ _GAS	t CO ₂ _GAS
1 Wh	0.2536	0.000254	2,536 * 10 ⁻⁷
1KWh	253.6	0.2536	0.000254
1MWh	253600	253.6	0.2536

Unit	Gallons/h	Gallons/min	
1 l/min	15.85	0.264172	
1 l/h	0.264172	0.004403	

Factors used for unit conversion, rounded to 6 positions after decimal point.

17 Accessories



Temperature sensors

The product range includes high-precision platinum temperature sensors, flatscrew sensors, outdoor temperature sensors, indoor temperature sensors, cylindrical clip-on sensors, also as complete sensors with immersion sleeve.

Sensor/VBus® extension cable, 100 m coil

Art. no.: 280 051 00



MicroSD card, incl. adapter

Art. no.: 112 121 86

18 Spare parts

Mains adapter 100–240V~ (12V=, 1A max)

Art. no.: 112 091 99

VBus® cable

Art. no.: 112 091 98

USB cable

Art. no.: 112 091 97

Distributed by:

RESOL – Elektronische Regelungen GmbH

Heiskampstraße 10
45527 Hattingen / Germany

Tel.: +49 (0) 23 24 / 96 48 - 0

Fax: +49 (0) 23 24 / 96 48 - 755

www.resol.com

info@resol.com

Important note

The texts and drawings in this manual are correct to the best of our knowledge. As faults can never be excluded, please note:

Your own calculations and plans, under consideration of the current standards and directions should only be basis for your projects. We do not offer a guarantee for the completeness of the drawings and texts of this manual - they only represent some examples. They can only be used at your own risk. No liability is assumed for incorrect, incomplete or false information and/or the resulting damages.

Note

The design and the specifications can be changed without notice.
The illustrations may differ from the original product.

Imprint

This mounting- and operation manual including all parts is copyrighted. Another use outside the copyright requires the approval of RESOL – Elektronische Regelungen GmbH. This especially applies for copies, translations, micro films and the storage into electronic systems.

© **RESOL – Elektronische Regelungen GmbH**